

# 3 VALVE MANIFOLD

## MMV TYPE

END CONNECTIONS:  
NPTF, BSPT, BSPP, Flanged

SIZE: 1/4" - 1/2"

Pipe to Flange Connections

CE APPROVED

ITEM	PARTS	QTY	MATERIAL
1	VALVE BODY	1	ASTM A182 F316
2	BONNET	3	AISI 316 (17-4PH)
3	BONNET PUSHER	3	AISI 316
4	STEM (TIP)	3	AISI 316
5	WASHER	3	AISI 316
6	PACKING	3	PTFE
7	BONNET SEAL	3	S.S
8	CHECK NUT	3	AISI 316
9	HANDLE	3	LDPE
10	DUST CAP	3	304 SST
11	ALLEN BOLT	3	S.S
12	LOCKING ARRANGEMNT	3	S.S
13	FLANGE GASKET	2	PTFE

### HOW TO ORDER

No. VLV  SIZE & END CONNECTIONS  MATL  PACKING MATL

MMV  -  -  -

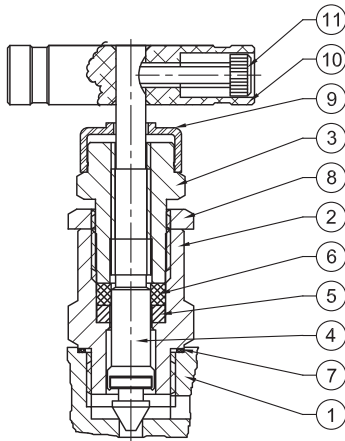

SECTIONAL DETAILS  
OF VALVE

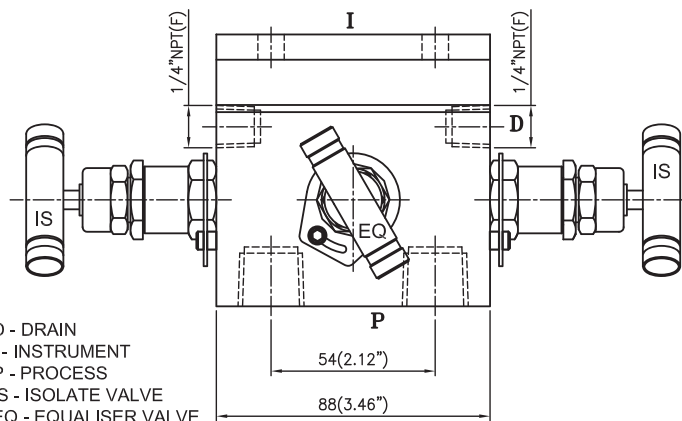

D - DRAIN  
I - INSTRUMENT  
P - PROCESS  
IS - ISOLATE VALVE  
EQ - EQUALISER VALVE  
BL - BLEED VALVE

