

UNION TEE, REDUCER FRACTIONAL  
(Two similar to a different run – X)

# UTRXF TYPE

SIZE: 1/16" – 1"  
\* END: Fractional tube (OD)



CE APPROVED

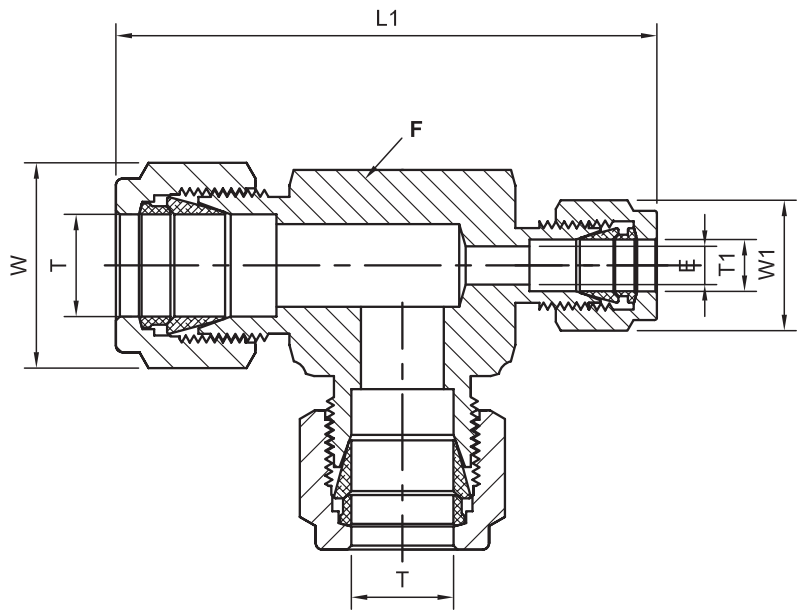

Part Number	Equivalent P/N	1 Equivalent P/N 2	Tube OD ØT (INCHES)	Tube OD ØT1 (INCHES)	ØE	D	C	L1	LY	LX	Body Hex F	Nut Hex W	Nut Hex W1
UTRXF-6-4-6	-600-3-4-6	6-4-6 JIZ	3/8	1/4	0.19	0.66	0.76	2.34	1.2	0.85	13/16	11/16	9/16
UTRXF-8-4-8	-810-3-4-8	8-4-8 JIZ	1/2	1/4	0.19	0.90	0.86	2.73	1.42	1.31	13/16	7/8	9/16
UTRXF-8-6-8	-810-3-6-8	8-6-8 JIZ	1/2	3/8	0.28	0.90	0.86	2.67	1.42	1.25	13/16	7/8	11/16
UTRXF-16-8-16	-1610-3-8-16	16-8-16 JIZ	1	1/2	0.41	1.23	1.04	3.7	1.94	1.76	1-3/8	1-1/2	7/8
UTRXF-16-12-16	-1610-3-12-16	16-12-16 JIZ	1	3/4	0.62	1.23	1.04	3.7	1.94	1.76	1-3/8	1-1/2	1-1/8

## NOTES:

- \* The "E" dimension is the minimum opening.
- \* Dimension "L1 & D" is shown in the finger-tight position.

- \* Dimensions are for reference only and are subject to change.
- \* **All part numbers are proprietary of their respective owners**