

UNION TEE, REDUCER FRACTIONAL
(Two similar to a different run – Y)

UTRYF TYPE

SIZE: 1/16" – 1"
* END: Fractional tube (OD)



CE APPROVED

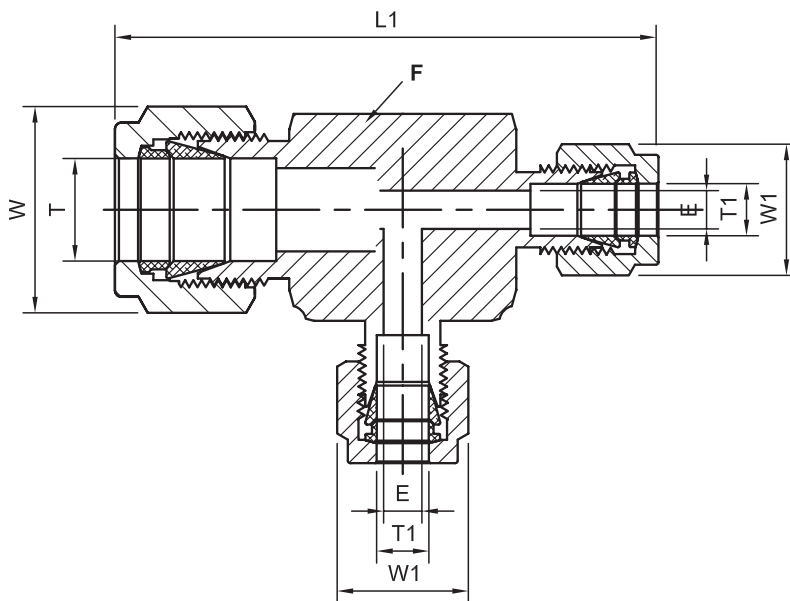

Part Number	Equivalent P/N 1	Equivalent P/N 2	Tube OD ØT (INCHES)	Tube OD ØT1 (INCHES)	ØE	D	C	L1	LX	Body Hex F	Nut Hex W	Nut Hex W1
UTRYF - 6-4-4	- 600-3-4-3	6-4-4 JIZ	3/8	1/4	0.19	0.66	0.76	2.34	1.14	13/16	11/16	9/16
UTRYF - 8-4-4	- 810-3-4-4	8-4-4 JIZ	1/2	1/4	0.19	0.90	0.86	2.67	1.25	13/16	7/8	9/16
UTRYF - 8-6-6	- 810-3-6-6	8-6-6 JIZ	1/2	3/8	0.28	0.90	0.86	2.73	1.31	13/16	7/8	11/16
UTRYF - 10-6-6	- 810-3-6-7	10-6-6 JIZ	5/8	3/8	0.28	0.96	0.86	2.95	1.42	1	1	11/16
UTRYF - 10-8-8	- 1210-3-8-8	12-8-8 JIZ	5/8	1/2	0.41	0.96	0.86	2.86	1.43	1	1	7/8
UTRYF - 12-6-6	- 1210-3-10-10	12-10-10 JIZ	3/4	3/8	0.28	0.96	0.86	3.03	1.46	1-1/16	1-1/8	11/16
UTRYF - 14-12-12	- 1610-3-14-14	16-14-14 JIZ	7/8	3/4	0.62	1.02	0.86	3.52	1.76	1-3/8	1-1/4	1-1/8
UTRYF - 16-6-6	- 1610-3-8-8	16-8-8 JIZ	1	3/8	0.28	1.23	1.04	3.59	1.65	1-3/8	1-1/2	11/16
UTRYF - 16-8-8	- 1610-3-6-6	16-6-6 JIZ	1	1/2	0.41	1.23	1.04	3.70	1.76	1-3/8	1-1/2	7/8
UTRYF - 6-4-4	- 600-3-4-3	6-4-4 JIZ	3/8	1/4	0.19	0.66	0.76	2.34	1.14	13/16	11/16	9/16
UTRYF - 8-4-4	- 810-3-4-4	8-4-4 JIZ	1/2	1/4	0.19	0.90	0.86	2.67	1.25	13/16	7/8	9/16

NOTES:

- * The "E" dimension is the minimum opening.
- * Dimension "L1 & D" is shown in the finger-tight position.

- * Dimensions are for reference only and are subject to change.
- * All part numbers are proprietary of their respective owners